

不燃性角形巻線固定抵抗器  
Non Flammable Square Wire-Wound Fixed Resistor

# SQL40W

- リードタイプ
- lead type
- RoHS対応品
- RoHS Complied



保守品

Service Supplies

■電氣的、機械的特性 Electrical and mechanical characteristics

| 特性<br>Characteristics                             | 規格値<br>Standards  | 試験方法<br>Test methods  |
|---|---|---|
| 抵抗値と抵抗値許容差<br>Resistance and Resistance tolerance | 抵抗値許容差<br>Resistance tolerance<br>1Ω ≤ R ± 5% (J)<br>1Ω > R ± 10% (K)       |   |
| 抵抗温度特性<br>Temperature coefficient                 | ±400ppm/°C max. (常温 Normal temp. ~ 常温 Normal temp.+ 100°C)                  |   |
| 定格負荷<br>Power rating load                         | △R/R ≤ ± (1%+0.05Ω)<br>最高表面温度 (Max. surface temp. rise) 315°C max.          |   |
| 短時間過負荷<br>Short-time overload                     | アーク焼損等の異常なきこと<br>No evidence of arc damage etc.<br>△R/R ≤ ± (2%+0.05Ω)      | 定格電力×10倍 5秒間負荷<br>1000% of rated power load for 5 seconds       |
| 絶縁抵抗<br>Insulation resistance                     | 20MΩ min.   | DC500V  |
| 耐電圧<br>Dielectric withstanding voltage            | 機械的損傷及び絶縁破壊なきこと<br>No evidence of mechanical damage or insulation breakdown | AC1500V for one minute  |
| 端子強度<br>Terminal strength                         | 機械的損傷なきこと<br>No evidence of mechanical damage                               | 引張り(Pull)<br>45N for 10±1 seconds                               |
| 抵抗体強度<br>Resistor strength                        | 機械的損傷なきこと<br>No evidence of mechanical damage                               | 98N for 10 seconds  |
| 耐振性<br>Vibration                                  | 機械的損傷なきこと<br>No evidence of mechanical damage                               | 1.5mm 10~55Hz/one minute<br>X and Y each directions for 2 hours |

■耐候的特性 Environmental characteristics

| 特性<br>Characteristics                          | 規格値<br>Standards  | 試験方法<br>Test methods  |
|--|---|---|
| 耐熱性<br>Heat resistance                         | 標印、絶縁被覆に著しい損傷なきこと<br>No deterioration of protective coatings or markings  | 350°C for 2 hours   |
| 熱衝撃<br>Thermal shock                           | 機械的損傷なきこと<br>No evidence of mechanical damage<br>△R/R ≤ ± (2%+0.05Ω)  | 定格負荷30分間 → -40°C 15分間<br>Power rating load for 30 minutes →<br>-40°C for 15 minutes           |
| 耐湿性 (定常状態)<br>Humidity (Steady state)          | 標印、絶縁被覆に異常なきこと<br>No deterioration of protective coatings or markings<br>△R/R ≤ ± (3%+0.05Ω)<br>絶縁抵抗 (Insulation resistance) 2.5MΩ min. | 成極DC100V<br>40°C 95%RH for 500 hours  |
| 耐久性 (耐湿負荷)<br>Durability (Moisture resistance) | 標印、絶縁被覆に異常なきこと<br>No deterioration of protective coatings or markings<br>△R/R ≤ ± (3%+0.05Ω)  | 10%負荷 10% of rated power load<br>90 minutes ON and 30 minutes OFF<br>40°C 95%RH for 500 hours |
| 耐久性 (定格負荷)<br>Durability (Nominal load)        | 標印、絶縁被覆に異常なきこと<br>No deterioration of protective coatings or markings<br>△R/R ≤ ± (5%+0.05Ω)  | 100%負荷 100% of rated power load<br>90 minutes ON and 30 minutes OFF<br>for 500 hours          |
| 難燃性 (過負荷)<br>Flame resistance (Over load)      | 燃焼しないこと<br>No evidence of flaming or arcing   | 定格電力の1~6倍<br>100~600% of rated power load   |

■規格 Standards

●形状・寸法 Configuration (mm)

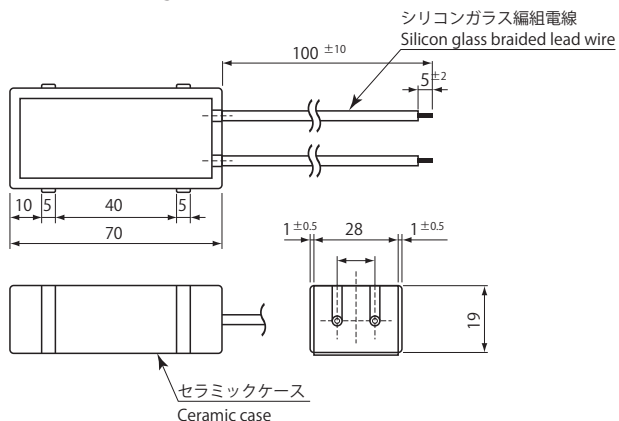

※取り付け金具につきましてはお客様毎のカスタム対応となります  
Attached metal bracket will be customized for each customer.

| 形状<br>Type | 定格電力 (W)<br>Power Rating | 抵抗値範囲 (Ω)<br>Resistance range |
|------------|--------------------------|-------------------------------|
| SQL40W     | 40                       | 0.36~1.6K(E24系)               |

●定格電力軽減曲線 Power Derating Curve

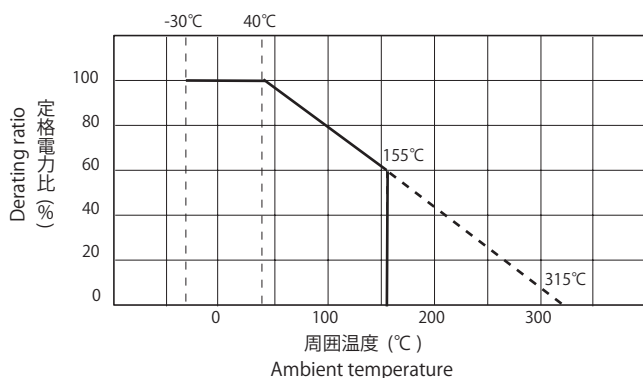

●表面温度上昇 Surface Temperature Rise

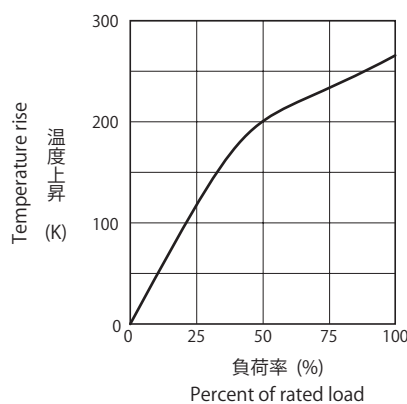

■カスタムオーダー品 products by order (Customized order made)

■最低ロット Minimum Order quantity 200個 200pcs

■品番コード Explanation of Part Number

SQLK 40W 4R7 J / RO

(個別仕様 Customer Specification)

